



Quad 60 Lube Skid

Refer to attached sales drawing: 800-20345 Rev 1

- 1. Three (3) 60 gallon new oil product tanks**
 - 12 gallon Mild steel constructed tanks on single platform
 - Tanks built to accommodate top and bottom suction
 - Includes top mount Rochester level gauge and 2" fill cap
- 2. New oil delivered via Lincoln 5:1 reciprocating air driven pump**
 - Rated at 6 gallon per minute free delivery
 - Pumps mounted on fixed shelf at rear of product tanks
 - Systems include 50' Hannay spring rewind hose reels with 50' of ½" pressure hose terminated with Lincoln 877 metered nozzle
 - Hoses mounted on upper shelf on rear of lube skid
- 3. One (1) 60 gallon waste oil tank**
 - 12 gallon Mild steel constructed tanks on single platform
 - Tanks built to accommodate top fill and bottom discharge
 - Includes top mount Rochester level gauge and 2" fill cap
- 4. Waste oil delivered via Lincoln 1" aluminum diaphragm pump**
 - Pump includes Lincoln 1" directional valve to allow single line suction and discharge of product
 - System includes Hannay 25' spring rewind hose reel with 25' of ¾" suction hose terminated with ¾" ball valve and 4" extension tube
 - Diaphragm pump and valve mounted on lower shelf of lube system with hose reel mounted beside
- 5. Air supplied through 3/8" regulator and teed to individual pumps**
 - Pumps controlled by 3/8" ball valves mounted in vicinity of reel
 - Customer is responsible for supplying air to Summit provided regulator
 - Air plumbing to pumps will be 3/8" minimum

SIZE	NUMBER	REV.
	800-20345	0

Features

1. 60 gallon new oil tank
2. 60 gallon new oil tank
3. 60 gallon new oil tank
4. 60 gallon waste oil tank
5. Lincoln 5:1 reciprocating pumps on all new oils
6. Lincoln 1" diaphragm pump on waste oil system
7. 1/2" x 50' Hannay spring rewind hose reels on all new products
8. 3/4" x 25' Hannay spring rewind hose reel for waste system
9. Lincoln air regulator and 3/8" ball valves to control air supply to pumps

REVISIONS			
REV	DESCRIPTION	DATE	BY

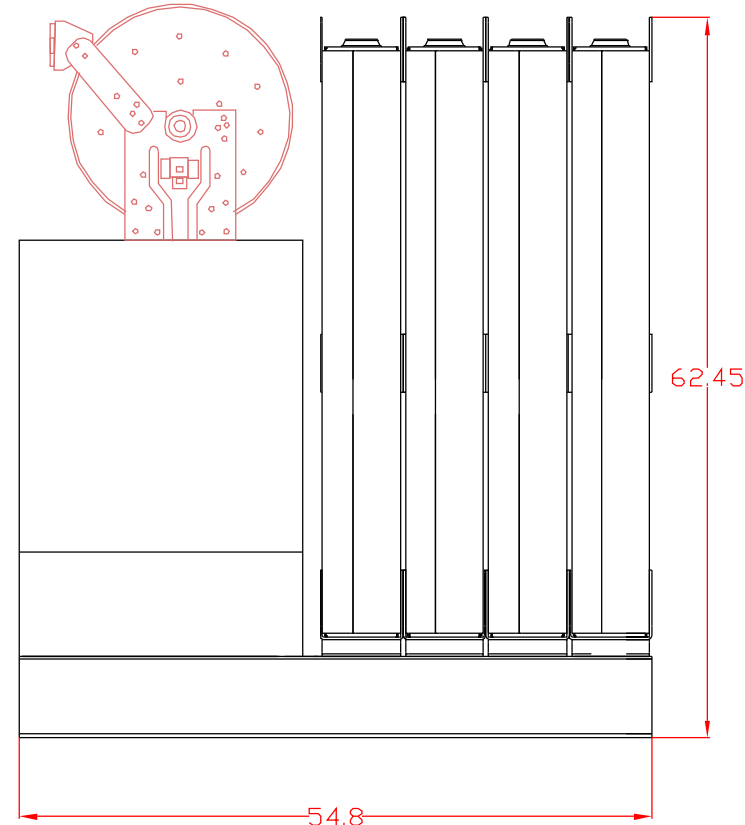
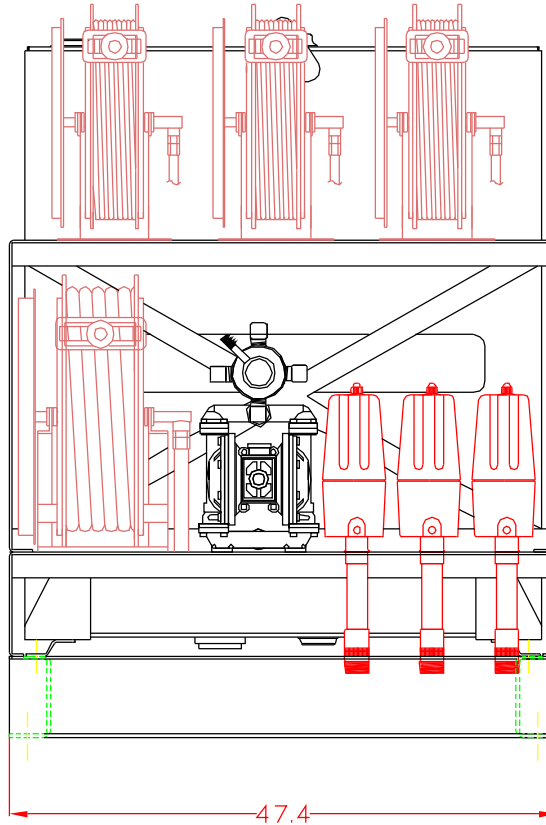

Custom Lube Skid	DRAWN Brent Thompson	CHECKED	 990 VERNON RD. WATHENA, KS. 66090 PHONE: (785) 989-3100 FAX: (785) 989-3563			
Page 1 of 1	DATE 1/11/07	APPROVED				
<small>NOTICE: THIS DRAWING CONTAINS PROPRIETARY INFORMATION. IT IS SUBMITTED IN CONFIDENCE AND IS TO BE USED SOLELY FOR THE PURPOSE FOR WHICH IT IS FURNISHED AND RETURNED UPON REQUEST. THIS DRAWING AND SUCH INFORMATION IS NOT TO BE REPRODUCED, TRANSMITTED, DISCLOSED, OR USED OTHERWISE IN WHOLE OR IN PART WITHOUT WRITTEN AUTHORIZATION.</small>	TOLERANCES UNLESS NOTED:		TITLE: Kris Eidsness Custom Lube Skid			
	DECIMAL----- ± .03	DECIMAL----- ± .015	SCALE	WEIGHT	SIZE	NUMBER
	ANGLES----- 1°	MACHINED SURFACES 125/				800-20345
	DO NOT SCALE THIS PRINT REMOVE ALL BURRS AND SHARP EDGES					REV.